

# THE INTERNATIONAL FLYING DUTCHMAN CLASS RULES

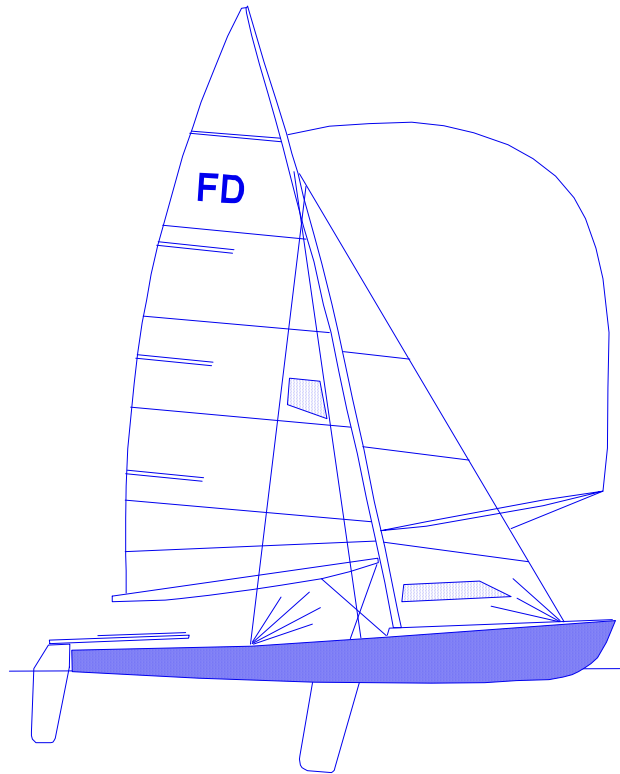

**MARCH 2016**



The Flying Dutchman was designed in 1951  
by Conrad Gulcher & Uus Van Essen  
and was adopted as an international class in 1952.  
The FD was the Olympic 2 man dinghy from 1960 to 1992

# THE INTERNATIONAL FLYING DUTCHMAN

## CLASS RULES

Version: FD-WS-7

Valid from 1 March 2016

	Rule Number		Rule Number
General	1-5	Foot straps	41
Advertising	1.4	Side deck pads	45
Builders	6	Buoyancy	44-47
International Class Fee / Sail Buttons	7	Trapeze	48-49
World Sailing (ISAF) plaque	7-12.3	Centreboard	50
Measurement Certificate & Form	8	Rudder	51
Owner's Responsibility/Subscription Sticker	9	Spars and Rigging	57-67
Sail Numbers	10	Mast	57-64
Measurers and Measurement Instructions	11	Boom	65-66
Measurement Procedure	12	Spinnaker pole	67
Hull	20-43	Bands	68-71
Construction and Shape	20-21	Fittings & Equipment	76-78
Length overall	22	Sails	80-110
Sections	23	Jib/Genoa	37-38, 92
Sheer	24	Mainsail	93-98
Stem	25	Battens	99-100
Transom	26-28	Spinnaker	102-108
Keel line measurements	29	Crew	111
Keelbands	30	Expensive Materials	112
Centreboard slot	31	Equipment Limitations	113
Deck	33	Wet Clothing	114
Section 9 Depth	34	Propulsion	115
Cockpit	35		Page
Rubbing Strake	36	Measurement Equipment	24
Jib/Genoa size	37-38	Appendices: A to K	25-35
Weight	39-43	Table of Offsets, L	36
Outriggers	40		

## GENERAL

### 1.0 Equipment and Racing Rules of Sailing

These class rules are **open class rules** and shall be read in conjunction with the Equipment Rules of Sailing (**ERS**) and the Racing Rules of Sailing (**RRS**).

The Measurement instructions, appendices and the measurement plan form part of these **class rules**. However, in the case of conflict the written **class rule** takes precedence. The object of these rules is to ensure that the boats of this class at all times conform to these **class rules**, within the tolerances, in shape and weight of **hull, centreboard, rudder and mast**, and shape of sail-plan.

Except where used in headings, when a term is printed in “**bold**” the definition in the ERS applies and when a term is printed in “**bold italic**” the definition in the **RRS** applies. Measurement instructions, within these rules, are in “*italic*” type.

### 1.1 Certification Authority

In alteration to ERS C.3.1 the Certification authority is the IFDCO, together with World Sailing.

### 1.2 World and Continental Championships

The IFDCO Championship Rules state: The measurement committee will be appointed by the **Organizing authority** from names to be submitted to the IFDCO Championship Organizing Committee for approval. The IFDCO chief measurer shall be President of the measurement committee (Principal Equipment Inspector).

### 1.3. Sailing Instructions

For World and European Championships, only the latest version of the World Sailing Standard Sailing Instructions, **RRS Appendix K**, as amended by the IFDCO and World Sailing to be in compliance with the FD Championship Rules, shall be used.

### 1.4. Advertising

Advertising is permitted in accordance with World Sailing Regulation 20, but in accord with World Sailing Regulation 20.3.2 is restricted to: (See Appendix A)

Hull	One advert on both sides of Maximum length 2250 mm, only 1513 mm aft of the stem point.
Mast	One advert on both sides of Maximum length 950 mm
Boom	One advert on both sides of Maximum length 470 mm
Mainsail OR Genoa	One advert on both sides, below the sail letters and numbers, of Mainsail Maximum length 1900 mm, Maximum width of 620 mm Genoa Maximum length 2300 mm, Maximum width of 620 mm.
Spinnaker	Unrestricted, but clearly separated from the sail letters and numbers.

## 1.5 Interpretation of the Class Rules - General

Interpretations of the class rules shall be made in accordance with the World Sailing Regulations except as provided by 1.6

## 1.6 Axes of Measurement (ERS section H.3)

The Flying Dutchman lines are specified by offsets in vertical and waterline planes. The CWL intersects the keel line at stations 0 and 10, thus the **Hull Datum Point (HDP)**, which is at the intersection of the plane of the transom and the keel line is 11 mm above the origin, which is on the CWL. The planes of the measurement templates, which are determined by points measured along the keel line and **sheerlines**, are therefore only ideally at the station planes.

2. In order to achieve the objective in Rule 1, the General Committee of the IFDCO reserves the right to exclude a **boat** from racing even if it measures within the letter of these rules, if the owner or builder has taken advantage of a loophole in the rules in order to build a **boat** which is different in shape and/or weight of **hull, centreboard, rudder, mast** or sail plan, from the plans of the class.

3. Alterations to the **Class Rules** shall be made in accordance with World Sailing regulation 10.11.

4. In the event of disputes the English text shall prevail. The words shall, must and will are mandatory. The word should is advisory and not mandatory. The words can and may are permissive.

5. The IFDCO issues plans, measurement instructions, and measurement equipment, but can never be held liable for faults, errors, omissions, and deviations.

## 6. Builders

Yachts of the Flying Dutchman Class may be built by any yard that has paid the required annual fee and acquired a license from World Sailing Ltd. On request, and after advice from IFDCO, builders who do not build more than two Flying Dutchman a year shall receive a free license from World Sailing Ltd. Yards and amateurs building shells only do not need a license.

## 7. International Class Fee

(Royalty, Building Fee) Payable by Licensed Builders.

7.1. The International Class Fee will be set by World Sailing in conjunction with IFDCO. Payment has to be directed to World Sailing Ltd. As receipt for the International Class Fee payment, a numbered World Sailing (ISAF) plaque will be sent by World Sailing and must be glued to the **boat** before **Fundamental measurement**:

- a. To the starboard forward bulkhead (just forward of the **mast**), or if this is not possible:
- b. To the starboard aft side of the aft bulkhead of a half double bottom, or if this is not possible:
- c. To the starboard side of the hog (vertical inner keel) about 300 mm from the transom, or if this is not possible:
- d. To the aft bulkhead of the cockpit.

## 7.2. Sail Buttons

Each **sail** manufactured after 1 September 1984 shall have permanently fixed near to its **tack** an officially numbered IFDCO sail button. No **sail** will be accepted for measurement without an IFDCO sail button. Buttons must not be transferred from one **sail** to another. The sail makers must obtain sail buttons from the IFDCO.

## 8. Certificate and Measurement Form

**Measurement certificates** are issued by the IFDCO after **fundamental measurement** by an IFDCO approved measurer, and receipt of the completed measurement forms.

**Measurement Forms:** A **certificate** and sail number will be issued only upon the receipt by the IFDCO registration of 2 of the original 3 measurement forms, each signed by the builder and an IFDCO measurer, which show that the **boat** fully complies with all the rules.

When the **boat** is measured outside the country of origin, it is desirable to have the signature of the builder, but not obligatory. When the **boat** proves to be within the rules, the 2 forms are to be signed by the IFDCO registration. One form is to be kept by the IFDCO Registration (white); one will go to the National Yachting Authority (green); or the National FD Class Association. The third copy (blue) may be kept by the measurer.

A certified photocopy of the measurement form will be part of the **certificate**. The **certificate** together with the certified photocopy of the measurement form must be produced upon demand at official FD regattas.

## 9. Owner's Responsibility

No **boat** shall take part in Class Races unless it has:

- a. A valid **certificate** and certified copy of the measurement form with Sail number, and World Sailing (ISAF) plaque number shown;
- b. Registration in the owner's name;
- c. A numbered World Sailing (ISAF) plaque glued to the **boat** at the required place;
- d. The **helmsman** and **crew** have IFDCO membership cards, with valid year stickers;
- e. A numbered IFDCO sail button on each **sail**;

## 9.1 Annual Subscription Sticker

A subscription sticker shall be sent by the National FD Secretary to every member who has paid his annual subscription, as a receipt. The National FD Secretary shall issue a membership card to each new member. The annual sticker shall be applied to this card as proof that the current subscription has been paid.

**9.2.** It is the owner's responsibility that a **boat** racing is fully certified and conforms to these rules and the spirit of the class in all respects, and that after alterations or modifications, the **boat** is re-measured where applicable.

***Warning:** In connection with this rule, which extends to major regattas also, owners are strongly advised to clear with the IFDCO Committee any point that may contravene the spirit of the rules.*

**9.3.** The **certificate** of a second-hand **boat** is invalid until it has been put in the name of the new owner and countersigned by the IFDCO registration, which will issue a new sail number in the event of a country change.

## 10 Sail Numbers

**10.1. Sail numbers**, preceded by the National Letters, shall be issued per country consecutively starting from 1.

### 10.2. Personal Sail Numbers

In accordance with **RRS Appendix G1.1(c)**, National Class Associations may issue personal sail numbers (Sail numbers staying with the owner for every **boat** he owns as long as he sails FD) this number must be shown on the personal IFDCO Membership Card. After the sale of the **boat**, the new owner must use the original sail number or his own personal number on his **sails**.

### 10.3. Hull numbers

The sail number of the **boat** must be shown on the transom. The height of the letters must not be less than a minimum of 30 mm

## 11 Measurers and Measurement Instructions

**11.1.** Measurers must be approved by the IFDCO in close co-operation with their National Yachting Authority (MNA).

**11.2.** A measurer shall not measure his own **boat**, a **boat** built by him or when he is in some way an interested party.

**11.3.** Only the owner and **crew** of the **boat**, the measurer, measurer's assistants, members of the Jury and the IFDCO Technical Committee may be present during measurement at a major regatta.

**11.4. Hulls** must be complete in every respect, and must have a World Sailing (ISAF) plaque (Rule 7.1) when presented for **fundamental measurement**. **Sails, masts** and other required gear may be measured separately.

**11.5.** Partly built **boats** can be partly measured, but the measurer must put under his signature - Partly measured - and must list on the measurement form the unmeasured items. The measurement form of such **boats** must also bear the name of the measurer who completed the measurement.

**11.6.** If measurers find deviations which do not contravene the exact letter of the rules but which might contravene the spirit of the rules, they must, before signing the measurement form, submit the matter to the IFDCO Executive Committee.

**11.7.** Only the IFDCO Executive committee can decide to give a waiver for a rule on which a **boat** deviates. The deviation and waiver are to be noted and countersigned by the IFDCO Chief measurer on the **certificate** and all 3 originals of the measurement form, before the **certificate** can be issued and become valid.

## 12 Hull Measurement Procedures

**12.1. Boats** shall be measured with official certified full FD templates, including their matched tie bars. The set number of the templates used for **fundamental measurement** shall be recorded on the measurement form.

**12.2.** The official templates will be issued by the IFDCO and World Sailing, and consist of 6 Hull shape templates with tie bars, 1 Stem template, 1 Transom angle-height template and 1 Sheer guard template. Each template must have the serial number of the set, must have been certified as correct and identified as such by a special mark made by the person appointed by IFDCO to check the templates.

*(numbers 13-19 are not used)*

## HULL

**20.** Deviations from the tolerances due to fair wear and damage, which do not affect the performance of the **boat**, shall not invalidate a **certificate** for a particular race, but shall be repaired, and put right as soon as possible.

**21.** Within the tolerances allowed, the **hull** shape must conform to the Mylar plan of the sections, stem and transom at full size and the master plan of lines and verticals to be controlled by the table of offsets. The skin curvature radius must not be less than a minimum of 75 mm, except within 100 mm from the keel band. Hollows exceeding 1 mm in depth in the keel or in the **hull** surface aft of section 7 are not allowed. (For the lines plan see Appendices J and K, and for the table of Offsets see Appendix L)

	Minimum	Maximum
Skin Curvature radius, except within 100 mm of keel	75 mm	
Hollows aft of station 7		1 mm

**22.** Overall hull length, measured along the deck line, is to be between 6040 mm and 6070 mm.

	Minimum	Maximum
Hull length along deck line	6040 mm	6070 mm

**23.** Body sections: transom, 1, 3, 5, 7 and 9 must be verified with official numbered templates applied in the manner shown in the measurement plan.

Tolerances: For the sections: transom, 1, 3, 5 and 7, the negative deviation must not exceed a maximum of 12.5 mm per section. For section 9, the positive deviation must not exceed a maximum of 12.5 mm. **Boats** built after 1 November 1981 have to conform to this rule.

Template gaps, measured in the template plane	Minimum	Maximum
Sections: transom, 1, 3, 5 & 7	12.5 mm	25.0 mm
Section 9	0 mm	12.5 mm

**Instruction:** See Measurement Plan. For sections transom, 1, 3, 5 and 7, the gap between template and **hull** must be between a maximum of 25 mm and a minimum of 12.5 mm. For section 9, the gap must be between a maximum of 12.5 mm and a minimum of 0 mm (i.e., templates touching the **hull**).

**24 Sheerline** height: The tolerance is plus 12 mm and minus 6 mm.

	Minimum	Maximum
Sheerline height tolerance	-6 mm	12 mm

**Instruction:** Template Position and Measuring method

a. After measuring the length, the **hull** is turned upside down and supported on trestles. The positions of the stations at the keel and the **sheerline** are to be determined by taking the following measurements from the outside of the transom along the keel and along the skin under the sheer guard.

<b>Station</b>	<b>1</b>	<b>2</b>	<b>3</b>	<b>4</b>	<b>5</b>	<b>6</b>	<b>7</b>	<b>8</b>	<b>9</b>
Keel line mark	732	1283	1835	2385	2936	3486	4036	4587	5137
Sheerline mark	745		1856		2958		4068		5210

b. Check at the same time the position and width of the centreboard slot (Rule 31). The station templates are set up on the keel and **sheerline** positions as found above (3 points per station). The adjustable lugs near the **sheerline** must be adjusted to have equal gaps on both sides between shell and template with the template centre at the centre of the keel band, or with equal sheer heights, whichever gives better results. One of the studs near the keel must touch the shell, with a tolerance of 2 mm for the other stud.



c. Check with a straight-edge (approx. 1000 mm long) for hollows aft of section 7. Small bumps or cut outs are also prohibited under this rule.

d. The **sheerline** height must be measured where the extended hull shell meets the top of the decking, by taking the vertical distance to the tie bar of the template. This distance must not vary more than a maximum of plus 6 mm or minus 12 mm from the distance of the sheer height mark on the template to the tie bar, with the exception of the stem template (See Rule 25).

## 25. Stem, Profile and Height

The gap between the hull and stem template, when positioned as per instruction 29a, shall be between zero and a maximum of 6 mm. The height of the stem point, i.e. the top of the stem, shall be within plus/minus 6 mm of the mark on the template. A bulbous stem is not permitted.

	Minimum	Maximum
Stem template gap	0 mm	6 mm
Stem point height tolerance	-6 mm	+6 mm

## 26. Transom

The height of the transom on the centreline, excluding the keel band, shall be between a minimum of 284 mm and a maximum of 296 mm. A hard chine transom is not permitted.

	Minimum	Maximum
Transom height above HDP	284 mm	296 mm

27. The transom must be placed at the extreme end of the **hull** and must be vertical to the waterline. The spacing between the transom template lug and the baseline controls this, and it must be between 5 mm and 15 mm.

	Minimum	Maximum
Transom template lug to baseline	5 mm	15 mm

28. No projections or apertures are permitted in the transom within 20 mm of the outside of the hull other than rudder pintles and 2 drain holes, each not larger than a maximum of 20 mm diameter. Corks or normal drain hole fittings protruding aft of the transom are allowed.

	Minimum	Maximum
Transom drain holes within 20 mm of outside of hull		20 mm

## 29. Keel line measurements

The shape of the keel line shall be checked by measuring the minimum distance to the baseline, which is the line drawn from a point 100 mm under the keel at the transom to

a point 120 mm under the keel at station 9. These minimum distances, “H” measurements, must be taken at each station:

<b>Station</b>	<b>1</b>	<b>2</b>	<b>3</b>	<b>4</b>	<b>5</b>	<b>6</b>	<b>7</b>	<b>8</b>	<b>9</b>
“H”	72	56	45	40	40	46	59	80	120

Tolerance: The absolute value of the algebraic difference between the maximum and minimum deviations including zero at station 9 must not exceed 12.5 mm.

	Minimum	Maximum
Absolute Diff. between the Max. & Min. H deviations		12.5 mm

### ***Instruction: Measuring Method***

*a. Put the stem-template with its lugs on the stem itself, not on the stem band, and the aft end of the template as much forward or aft of station 9 as the hull is respectively longer or shorter than 6055 mm overall (measured under rule 22). The gap between the template and the stem is nowhere to exceed a maximum of 6 mm or be less than zero.*

*b. For measuring the height of the stem, the lugs must be placed on the stem itself, not on the stem band. (If the stem band is not visible a minimum thickness of 3 mm, together with a width of 6 mm, shall be accepted as such). The stem point, i.e. the top of the stem must be between the height marks on the template.*

*c. Put the transom height-angle template on the bottom of the hull next to the keelband. The top of the transom must then be between the maximum and minimum height marks on the template. Then put the transom template on the keel (not on the keelband) together with the stem template also on the keel. Using the triangular-shaped holes in the templates, draw a string tight between the templates. This is the baseline. The gap between the lug on the arm of the transom angle template and the string must be between 5 and 15 mm (see Appendix B, Measurement Plan for directions).*

*d. Now take the H measurements between the baseline and the keel.*

*e. When the thickness of the keelband is consistent, the stem and transom templates may be put on the keelband and the H measurements must then be taken between the base line and the keelband.*

## **30. Keelbands**

Keelbands of metal, hardwood, plastic or glass-reinforced plastic must be fitted and must measure between 3 and 10 mm in thickness and between 6 and 15 mm in width. The keelband must run the full length of the hull along the keel including the stem to form a stem band.

If the keelband is faired into the hull so that its width and thickness cannot be determined, the junction between the hull and the keelband shall be taken such that the dimensions of the assumed keelband conform to the above limits, that is, at least 6 mm wide and 3 mm thick.

Adjacent to the centreboard slot, the keelband must be duplicated and must clearly overlap the centre keelband but by not more than a maximum of 50 mm at each end. Keelband joining fishplates are permitted.

	Minimum	Maximum
Keel band thickness	3 mm	10 mm
Keel band width	6 mm	15 mm
Keel band overlap at C/B slot	0 mm	50 mm

### 31. Centreboard slot

The aft end of the centreboard slot must be between 2000 and 2106 mm and the forward end must be between 3396 and 3408 mm from the transom station.

The width of the slot must not exceed a maximum of 40 mm.

	Minimum	Maximum
Aft end of C/B slot to HDP	2000 mm	2106 mm
Forward end of C/B slot to HDP	3396 mm	3408 mm
Width of C/B slot		40 mm

*(number 32 is not used)*

### 33. Deck

The deck shall not be higher than the deck line and shall be below the deck line at the mast partners. The deck line is the imaginary line between the top of the transom at the centreline and the stem point, that is, the highest point on the deck at the stem. (excluding stem fittings).

	Minimum	Maximum
150 mm reference line to deck	150 mm	

***Instruction:*** Erect a taut reference line 150 mm above both the stem point and the top of the transom, i.e. parallel to the deck line. The mast partners and the rest of the deck must be at least 150 mm below this line.

**34.** The depth from the deck line to the keel line at section 9 must be between a minimum of 603 mm and a maximum of 615 mm.

	Minimum	Maximum
Depth from the deck line to the keel line at section 9	603 mm	615 mm

***Instruction:*** This is checked by applying the station 9 template and measuring the distance between the tie bar lower edge, which shall be 90 mm above the sheerline marks, and the reference line used for checking the height of the deck. The vertical distance shall be between 90 and 102 mm. Note that if the stem and transom templates are used to establish the reference line then the height mark arrow on the stem

*template must be adjacent to the stem point while the upper limit mark on the transom template must be at the top of the transom (the triangular aperture to height mark arrow distance on the transom template is 156 mm while on the stem template it is 150 mm) (See Appendix B Measurement Plan)*

### 35. Cockpit

The area of the **hull**, including spinnaker holes, not covered by fixed decking must be between a minimum of 1.5 m<sup>2</sup> and a maximum of 4.2 m<sup>2</sup>. Fixed decking is decking which is screwed, nailed, glued or moulded-in with the **hull**, which must not be removable during the race and which lies above or at the same level as the sheer height.

	Minimum	Maximum
Area of <b>hull</b> not covered by fixed decking	1.5 m <sup>2</sup>	4.2 m <sup>2</sup>

***Instruction:** To find the limits of the cockpit area, a straight edge shall be laid across the cockpit. Measure the distance between the straight-edge and the sheer. The limit of the cockpit is where the inboard side of the side deck is at the same distance from the straight-edge as the sheer. It may be necessary to use Simpson's rule to determine the area. (See Measurement Plan, Appendix B)*

### 36. Sheer Guards (Rubbing Strakes)

All **hulls** must be fitted with sheer guards (rubbing strakes) along the full length of the **hull** at the **sheerline**, which must nowhere measure more than a maximum of 50 mm or less than a minimum of 5 mm perpendicular to the hull shell and parallel to the hull shell more than a maximum of 35 mm or less than a minimum of 10 mm. The sheer guard is to be placed along the topsides at the sheerline. The width of a rubbing strake across the transom if fitted and/or forward of the stem must not exceed a maximum of 12.5 mm.

	Minimum	Maximum
Width of sheer Guard	5 mm	50 mm
Height of sheer Guard	10 mm	35 mm

***Instruction:** A sheerline template is to be used to locate the sheer points on the surface of the deck and to check maximum sheer guard dimensions. (See the measurement Plan).*

*Callipers are to be used to check minimum dimensions.*

**37.** The bearing point of the jib **sheet** on its fairlead must be forward of a plane perpendicular to the deckline and 2000 mm along the deckline from the **transom**. It must be impossible to fix the bearing point of the jib sheet on its fairlead, or to extend the operational clew cringle of the jib, aft of this plane. The bearing point of the jib sheet on its fairlead must not exceed a maximum of 60 mm above the upper side of the deck. The bearing point of the jib sheet is the after most point of the bottom of the groove of a

sheave, or the forward side of the opening of a fairlead for the jib sheet. (See Appendices C and D)

	Minimum	Maximum
Bearing point of jib sheet to transom, along deckline	2000 mm	

**38.** When the **boat** is fully rigged with mast vertical, **sails** hoisted in racing trim and sheeted for windward sailing, no part of the jib luff wire, excluding cringles, shall project more than 5 mm forward as measured perpendicular to the luff, of an imaginary line drawn from a point on the deck line a maximum 5450 mm from the aft side of the transom to a point on the front of the **mast** at a maximum 5250 mm above the deck line, that is below the lower edge of **Limit mark** (band) number 4. (See Appendices D and E)

	Minimum	Maximum
Intersection of jib luff wire forward edge with deck line, to transom		5450 mm
Intersection of jib luff wire forward edge with mast forward edge, to deck line		5250 mm
Jib/Genoa luff wire forward edge forward of line		5 mm

### 39. Weight

The **hull weight**, including all fixed and movable fittings (including trapeze hooks, shroud length adjustment systems, and baby stays), buoyancy apparatus as prescribed in Rules 44-47 (whether removable or fixed) and running gear, but not including main, Genoa and spinnaker sheets, shall not be less than a minimum of 130.0 kg.

	Minimum	Maximum
<b>Hull weight</b> , including all fixed and movable fittings	130.0 kg	
<b>Hull corrector weights</b>		15.0 kg

### 40. Outrigger

In contravention to **RRS 50.3**, an outrigger, of maximum 60 mm outside the **hull** and not more than a maximum of 500 mm from the shrouds, is allowed for leading the spinnaker guy.

	Minimum	Maximum
Outrigger outside the <b>hull</b>		60 mm
Outriggers from the shrouds		500 mm

### 41. Foot straps

Foot straps, which support the crew's feet, further outboard than the sheer guards (rubbing strakes) are prohibited.

### 42. Corrector weights

If the **hull** as weighed in Rule 39 weighs less than 130.0 kg, lead **corrector weights** must be permanently fastened to the underside of the deck, forward of the **mast**, be

easily visible and stamped by the measurer. The actual weight must be stated on the measurement form. No **boat** shall carry more than a maximum of 15.0 kg of **corrector weights**.

**43. The corrector weights** may only be adjusted to comply with the minimum **hull weight**, Rule 39, after a measurement by an IFDCO approved measurer. The amount removed shall be marked on the measurement form and certified by the measurer.

#### 44. Buoyancy

The **boat shall float** its own weight when all buoyancy tanks or bags have been removed or filled with water. **Boats** built of non-buoyant material shall have rigid buoyancy made of closed cell foam plastic, or similar buoyant material, which is permanently attached to the **hull**. Buoyancy tanks or bags shall provide a minimum of 220 kg of positive buoyancy. At least two completely independent buoyancy tanks or bags, of at least 50 kg buoyancy each, are required.

	Minimum	Maximum
Hull positive buoyancy	220 kg	
Number of independent tanks of Minimum 50 kg	2	

***Instruction:** Volume of buoyancy should be 0.22 m<sup>3</sup> of air or 0.28 m<sup>3</sup> for Styrofoam or similar material.*

#### 45. Side Deck Pads

Detachable side deck pads, are allowed aft of the bearing point of the jib sheet (Rule 37) but must not project outside of the maximum permitted width of the sheer guards (rubbing strakes) (Rule 36).

**46. Buoyancy apparatus** must be kept securely fastened and fully effective at all times.

**47.** The buoyancy must be fitted to the **hull** such that in the event of complete flooding, the **boat** will float approximately level with an effective weight of not less than a minimum of 220 kg placed at a point between the **mast** and a position 1500 mm aft of the **mast**.

### TRAPEZE and APPENDAGES

#### 48. Trapeze

**RRS 49.1** is amended to allow a Trapeze, which consists of 2 wires or lines attached directly or indirectly to the **mast**, one on each side, which can be fastened to a trapeze harness. The trapeze shall not be used to support more than one person at a time. The weight of the trapeze hooks, handles, rings, and gear to adjust the length between the trapeze wire or line and the trapeze harness, must not exceed a maximum of 1.0 kg.

	Minimum	Maximum
Weight of the trapeze hooks, handles, rings, etc.		1.0 kg
Weight of the trapeze harness		4.0 kg
Trapeze quick release time		2 sec

**49. The trapeze harness** may be attached directly or indirectly to a trapeze wire or line but only by means of a single quick release system (2 seconds). The weight of the trapeze harness must not exceed a maximum of 4.0 kg and shall float after complete immersion. The trapeze harness is separate from, and shall not constitute a **personal Floatation Device (PFD)**, as required by rule 78.

## 50. Centreboard (See Appendix F)

**50.1** The shape of the under hull part of the **centreboard**, in its lowest position, must conform to the profile as defined in Appendix F. With the leading edge fully up against the leading edge line, within a tolerance of maximum 3 mm for local gaps, the tolerance is plus or minus 6 mm on the bottom and trailing edges and on the curves at the bottom of the **centreboard**.

A stop must be fitted on the **centreboard** to prevent it from being lowered farther than a maximum of 1060 mm under the **hull**. The use and position of a centreboard bolt, notch or holes are optional.

**50.2.** The weight of the complete **centreboard** including blocks of maximum combined weight of 300g, must not be less than a minimum of 5.50 kg.

**50.3.** Thickness of the under hull part of the **centreboard** must not exceed a maximum of 23.0 mm.

**50.4.** It must be possible to raise the **centreboard** into its case by rotating it so that the leading edge of the **centreboard** is close to and approximately parallel to the keel line.

**50.5.** When it is fully or partly lowered, no part of the **centreboard** shall be aft of the extension of that part of the trailing edge that is below the **hull**. (See Appendix F)

	Minimum	Maximum
C/B profile deviation from Appendix F outline		6 mm
Depth of C/B under the <b>hull</b>		1060 mm
Weight of the complete <b>centreboard</b>	5.50 kg	
Thickness of the under hull part of the <b>centreboard</b>		23.0 mm

## 51. Rudder (See Appendix F)

**51.1** The shape of the part of the **rudder** blade, when in its lowest position, which is situated under the extended keel line, must conform to the profile as defined in Appendix F. With the leading edge fully up against the leading edge line, within a tolerance of maximum 3 mm for local gaps, the tolerance is plus or minus 6 mm on the

bottom and trailing edges, and on the curves at the bottom of the **rudder**. (See Appendix F)

**51.2.** The total weight of the complete **rudder** including fittings, tiller and tiller extension must not be less than a minimum of 4.00 kg.

**51.3.** The part of the **rudder** projecting under the extended line of the keel must not project under this line more than a maximum of 810 mm. (See Appendix F)

**51.4.** The leading edge of this part of the **rudder** shall make an angle that must not exceed a maximum of 105 degrees with the keel line. When racing, **boats** with lifting rudder blades must fix the position of the leading edge as above by means of a pin, unless a special exception is made in the sailing instructions. (See Appendices B and G)

**51.5.** The distance from the leading edge of the **rudder**, at the point of intersection with the extended keel line, must not exceed a maximum of 60 mm from the transom. (See Appendices B and G)

**51.6.** A safety device must be fitted so that the **rudder** cannot come off unintentionally if the **boat** is inverted.

**51.7. Tiller** The tiller may extend aft of the transom not more than a maximum of 1000 mm.

**51.8.** Double **rudders** and **rudders** fully or partly forward of the plane of the **transom** are prohibited. **Trim tabs**, lifting foils or similar contrivances, attached to the **rudder** and/ or transom are prohibited.

	Minimum	Maximum
<b>Rudder</b> profile deviation from Appendix F outline		6 mm
Depth of <b>rudder</b> under the <b>hull</b>		810 mm
Weight of <b>rudder</b> including fittings, tiller & extension	4.00 kg	
Angle of <b>rudder</b> leading edge with keel line		105 deg
Leading edge of the <b>rudder</b> to transom		60 mm
Tiller extension aft of the transom		1000 mm

*(numbers 52-56 are not used)*

**SPARS and RIGGING** (See Appendices D, E and F)

**57. Mast.** Rotating **masts** are prohibited.

The **Mast Spar Curvature** shall be less than 20 mm.

**58.** The **weight** of the **mast** (excluding trapeze hooks, shroud length adjustment systems, and baby stays, but including a compass bracket and shroud rollers of combined maximum weight less than 400g) shall not be less than a minimum of



8.50 kg. Mast **corrector weights** of lead shall be permanently attached to the **mast** above **limit mark** (band) No. 1.

The height of the centre of gravity of the **mast** must not be less than a minimum of 2500 mm above the top of **Limit mark** (band) number 1.

***Instruction:** For the mast CG measurement the halyards must be in their sailing position. The shrouds, forestay and trapezes must be stretched along the mast and attached at a point 2500 mm above the top of the **Limit mark** (band) number 1. Those parts of the rigging below this point may be supported. When a knife-edge at 2500 mm above band 1 supports the mast it must tip, **Top point** down.*

**59.** The **mast** must have openings near the top and the heel to allow the **mast** to drain. The sum of the areas of the openings at the top and at the heel must not be less than a minimum of 150 mm<sup>2</sup>.

	Minimum	Maximum
<b>Mast Spar Curvature</b>		20 mm
<b>Weight</b> of the <b>mast</b> (excluding trapeze hooks etc.)	8.50 kg	
Height of <b>mast</b> CG above <b>Limit mark</b> 1	2500 mm	
Sum of areas of drain openings at top and heel	150 mm <sup>2</sup>	
Mast heel measurement point to transom		3600 mm

**60. Mast Spar Cross-Section**, including the sail track or its extension, for the sections:

	Minimum	Maximum
From the <b>heel</b> to the <b>limit point</b> No 4, fore and aft	70 mm	100 mm
From the <b>heel</b> to the <b>limit point</b> No 4, transverse	50 mm	100 mm

**61. Mast Position:** A stop must be fitted at the mast step to prevent the “mast heel measurement point” from being moved aft of a point perpendicularly down from the deck line and 3600 mm from the transom, as measured along the deck line. The mast heel must be on the centreline. Slides or carriages on the mast heel track are prohibited. (See Appendix D)

**62. Mast Rigging: Running backstays** and rigid forestays are prohibited, and only a single adjustable centreline **backstay** is allowed. All **shrouds** must be installed such that movement of their lower ends is impossible while racing. A flexible or solid baby **stay**, if fitted, must not be attached higher than the **Lower point**, i.e. the upper edge of band number 2 (see Rule 68).

**63.** A forestay, of minimum diameter 2.00 mm, and of material of strength equivalent to stainless steel wire, shall be rigged. The position of the forestay shall be forward of the **luff** of the jib and within 200 mm of the centre line, see **RRS 54**. The forestay must be independent of the jib, and must support the **mast** when the jib is lowered, or the jib halyard or **tack** is broken in a strong wind. The measurer must be convinced of a seaman-like job, also under the foredeck.

	Minimum	Maximum
Forestay diameter	2.00 mm	

**64.** It must normally be possible to lower the main and the jib from the cockpit, while the **mast** is standing in its normal sailing position.

**65. Boom.** Permanently bent **booms** are prohibited.

**66.** The **boom**, without fittings, must be able to pass through a circle having a diameter of 150 mm.

**67.** The **Spinnaker Pole** length must not exceed a maximum of 2500 mm. The **spinnaker pole fitting projection** must not exceed a maximum of 50 mm.

	Minimum	Maximum
<b>Boom</b> diameter		150 mm
<b>Spinnaker Pole</b> length		2500 mm
<b>Spinnaker pole fitting projection</b>		50 mm

**68. Limit marks** must be bands around the whole spar, of minimum **limit marks width** 10 mm, white or yellow on black masts, in contrasting colour for other **spars**, and except for **Limit Mark** 1 which shall be below deck level, must remain visible while racing. The relevant edge shall be as follows:

- No 1: The upper edge of this **limit mark** (band) must be under the deck level at the **mast**.
- No 2: The **Lower point (Mast Datum Point)**, the upper edge of the **Lower limit mark** (band) must be less than a maximum of 800 mm above the upper edge of band No 1.
- No 3: The **Upper point**, the lower edge of the **Upper limit mark** (band) must be less than a maximum of 6400 mm above the **lower point** (upper edge of band No 2).
- No 4: The lower edge of this **limit mark** (band) must be less than a maximum of 5250 mm above the upper edge of band No 1.
- **Boom Outer point**, the inner edge of the **Outer limit mark** (band) must be less than a maximum of 2840 mm from the aft side of the **mast**. (See Appendix E)

	Minimum	Maximum
<b>Lower point</b> to upper edge of the <b>Lower limit mark</b>		800 mm
<b>Upper point height</b>		6400 mm
Lower edge of <b>limit mark</b> 4 to upper edge of band 1		5250 mm
<b>Outer Point Distance</b>		2840 mm
<b>Boom spar</b> axis to aft edge of <b>mast spar</b>		90 mm

**69.** Contrary to **ERS F.2.3 (j)** the final bearing point of the spinnaker halyard on its fairlead or sheave must be below and aft of the line from a point on the forward edge of the **mast** 500 mm above the lower edge of the No 4 band, to a point 160 mm forward (measured perpendicular to the forward edge of the **mast**) of the lower edge of the No 4 band. (See Appendix E)

**70.** The extension of the top of the **boom**, when perpendicular to the **mast**, shall not cross the **mast** at a point lower than the **Lower point**, i.e. the upper edge of the band number 2. A stop on the **boom** shall prevent the **clew point** of the **mainsail** from extending beyond the **outer point**. (See Appendix E)

**71.** Except when in the center plane of the mast **spar**, the central axis of the boom **spar** shall intersect the mast **spar** center plane at a distance of not more than 90 mm from the aft edge of the mast **spar**.

**72.** Loose footed mainsails shall have a system to prevent the **clew point** to be positioned more than 60mm from the boom **outer point**. To achieve this, the clew outhaul shall pass under a strap positioned at or forward of the plane of the **outer limit mark**.

*(numbers 73-75 are not used)*

## **FITTINGS and EQUIPMENT**

**76.** The use of hydraulic, pneumatic and electrical/electronic devices and instruments while racing is prohibited except that, when mandated by the NoR and SIs, VHF radios may be carried. However, while racing VHF radios, cell phones or other electronic devices may only be used for communication with the RC, except in emergencies.

**77.** Electronic timing devices and magnetic and electronic compasses are permitted, provided they do not correlate simultaneous data. Devices using the GPS and providing data to the competitor, while racing, are prohibited.

**78.** The following must always be carried on board:

- 2 paddles, minimum length 1000 mm; each of minimum weight 0.25 kg.
- A **Personal Floatation Device (PFD)** for each crew member to the minimum standard ISO 12402-5 (Level 50), or USCG Type II or III, or AUS PFD 1. The Notice of race or Sailing Instructions may prescribe alternative requirements.
- 1 towing line, synthetic material, minimum diameter 8.0 mm, minimum length 15.0 m and dry weight not less than a minimum of 0.50 kg.

An anchor plus anchor line are required only when and as specified in the Notice of Race and/or in the Sailing Instructions.

	Minimum	Maximum
Two paddles length each	1000 mm	
Two paddles weight each	0.25 kg	
Two <b>personal buoyancy</b> aids of buoyancy	50 N	
Tow line length	15.0 m	
Tow line diameter	8.0 mm	
Tow line weight	0.50 kg	

*(number 79 is not used)*

## SAILS

**80.** The dimensions given on the sail plan are maximum, except the measurement giving the position of the top batten (minimum dimension). **Sails** must be of **woven ply** (Mylar or Kevlar are prohibited, see Rule 112.).

**81.** All **sails** must be **single woven ply**. The body of the mainsail and the Genoa must each be of a single colour except for **sail windows**, and markings in accordance with **RRS 77 and Appendix G**. Reinforcements are permitted without limitation but it must be possible to fold the **sail**, including reinforcements, by hand in any direction within an outside diameter of 8.0 mm.

**82. Double luff sails** are prohibited.

**83.** Sail openings, except eyelets, cringles and **windows**, are prohibited. **Windows** made of any material and with a total area that must not exceed a maximum of 1.00 m<sup>2</sup> in each **sail** are permitted, but only in the mainsail and in the Jib/Genoa.

*(number 84 is not used)*

### 85. Emblems - Sail Letters – Numbers

The class emblem shall be the letters **FD**. The sail number, letters and class emblem must be in accordance with the **RRS Appendix G**. In addition to **RRS Appendix G1.1(b)** mainsails must carry national letters in home waters. **RRS Appendix G1.1** is modified such that national letters and sail numbers are not required on either Genoas or spinnakers.

**86. After** a **sail** has passed measurement, the measurer shall stamp and sign the **sail**.

### JIB/GENOA *(Note Rules 37 and 38 repeated for convenience)*

**37.** The bearing point of the jib **sheet** on its fairlead must be forward of a plane perpendicular to the deckline and 2000 mm along the deckline from the **transom**. It must be impossible to fix the bearing point of the jib sheet on its fairlead, or to extend the operational clew cringle of the jib, aft of this plane. The bearing point of the jib sheet on its fairlead must not exceed a maximum of 60 mm above the upper side of the deck. The bearing point of the jib sheet is the after most point of the bottom of the groove of a

sheave, or the forward side of the opening of a fairlead for the jib sheet. (See Appendix C and D)

	Minimum	Maximum
Bearing point of jib sheet to transom, along deckline	2000 mm	

**38.** When the **boat** is fully rigged with mast vertical, **sails** hoisted in racing trim and sheeted for windward sailing, no part of the jib luff wire, excluding cringles, shall project more than 5 mm forward as measured perpendicular to the luff, of an imaginary line drawn from a point on the deck line a maximum 5450 mm from the aft side of the transom to a point on the front of the **mast** at a maximum 5250 mm above the deck line, that is below the lower edge of **Limit mark** (band) number 4. (See Appendices D and E)

**87.** No part of the jib/Genoa shall extend more than 10 mm in front of the forward edge of the luff wire when the luff is tensioned.

	Minimum	Maximum
Intersection of jib luff wire forward edge with deck line, to transom		5450 mm
Intersection of jib luff wire forward edge with mast forward edge, to deck line		5250 mm
Jib/Genoa luff wire forward edge forward of line		5 mm
Jib/Genoa extent forward of the LE of the luff wire		10 mm

*(numbers 88-89 no longer used)*

**90. RRS 50.4** shall not apply

**91.** Elastic strips and regulating cords in or attached to the **foot** of the jib or Genoa are prohibited.

**92.** No headboard, battens or foot club are allowed in the jib.

*(numbers 93 and 94 are not used)*

**MAINSAIL** (See Appendices H and I)

**95.** The **mainsail top width** shall not exceed a maximum of 150 mm. (See Appendix H)

**96.** The mainsail when set must lie between the **upper point** and the **lower point** on the mast and the **outer point** on the **boom**, i.e. between the bands.

**97.** The **leech length** must not exceed a maximum of 6800 mm.

**98.** The **upper width** of the mainsail is the shortest distance from the **upper leech point**, which is 3400 mm from the **head point**, to the **luff**, and must not exceed a maximum of 1900 mm.

**99.** The extension of the upper edge of the inside of the upper **batten pocket** must meet the **luff** at a point a minimum of 1500 mm from the **head point** (the **luff** being stretched so as to remove wrinkles in the material of the **sail**). The distance from this point to the **leech**, measured along the inner edge of the upper batten pocket must not exceed a maximum of 1010 mm. (See Appendix H)

**100.** A maximum of 4 sail battens are permitted in the mainsail. The **batten pockets** must divide the **leech** into equal parts plus or minus 100 mm. The **batten pocket inside widths** must not exceed a maximum of 60 mm. The **batten pocket inside lengths** must not exceed a maximum of 1000 mm.

**101.** The **mainsail foot median** shall not exceed a maximum of 6700 mm. (See Appendix G)

	Minimum	Maximum
<b>Mainsail top width</b>		150 mm
<b>Mainsail leech length</b>		6800 mm
<b>Mainsail upper width</b> at 3400 mm		1900 mm
<b>Head point</b> to the intersection of upper edge of the inside of the upper <b>batten pocket</b> with the <b>luff</b>		1500 mm
<b>Leech</b> to the intersection of upper edge of the inside of the upper <b>batten pocket</b> with the <b>luff</b>		1010 mm
<b>Mainsail Foot Median</b>		6700 mm

**SPINNAKER** (See Appendix I)

**102.** Spinnakers must be symmetrical in form and construction.

**103.** The **luff lengths** must not exceed a maximum of 5500 mm.

**104.** The **Foot median** must not exceed a maximum of 6600 mm.

**105.** The straight-line distance from the **Clew points** to the **Mid foot point** must not exceed a maximum of 2050 mm. The **Foot Irregularity** must not exceed a maximum of 20 mm.

**106.** The **upper leech points** are at 2750 mm from the **head point**. The spinnaker **upper width** must not exceed a maximum of 3950 mm.

**108.** The spinnaker headboard must not exceed a maximum of 150 mm in any direction.

	Minimum	Maximum
Spinnaker <b>luff lengths</b>		5500 mm
Spinnaker <b>Foot median</b>		6600 mm
spinnaker <b>upper width</b> at 2750 mm from <b>head point</b>		3950 mm
Spinnaker <b>Clew points</b> to the <b>Mid foot point</b>		2050 mm
Spinnaker <b>Foot Irregularity</b>		20 mm
spinnaker headboard in any direction		150 mm

(numbers 107, 109-110 no longer used)

## CREW and EQUIPMENT

**111.** The **crew** must consist of two persons.

### 112. Expensive Materials

Unusually expensive materials or equipment shall be deemed to be contrary to the spirit of the class and may be prohibited. Before using such materials and/or equipment, permission must be obtained from the General Committee of the IFDCO. Composite materials such as those incorporating boron and other materials of limited availability are prohibited. Carbon fibre (fibres of graphite) and/or aromatic polyamides (aramids) such as Kevlar (Dupont trade name) are prohibited in the **body of the sail**.

### 113. Equipment Limitation

a) The equipment limitations specified in section c) shall apply to Flying Dutchman World and European Championships but are discretionary for all other regatta series. In other regatta series, certain limitations regarding equipment may be enforced when the notice of race and sailing instructions contain the following provisions: "This regatta series named \_\_\_\_\_ from \_\_\_\_\_ to \_\_\_\_\_ has limitations as to equipment in accordance with Rule 113."

b) Definition of regatta series: A regatta series is a number of races scheduled to be sailed on consecutive days (one or two days or rest days or non-sailing days do not break the sequence) or on two consecutive weekends or long weekends, for one points prize or title.

c) The limitations regarding equipment for a series are:

1 mainsail, 1 spinnaker, 2 Genoas, 1 **mast**, 1 **boom**, 2 **spinnaker poles**, 1 **centreboard**, 1 **rudder**.

d) If there is any damage to the equipment as mentioned under subparagraph c), it is at the discretion of the jury to allow replacements.

e) Marking limited equipment: The equipment mentioned in c) shall be identified by clearly visible markings, which cannot be transferred to other equipment.

**114. Wet Clothing Weights** are to be determined as specified in **RRS Appendix H** and must be as specified below:

**Crew:** Total weight of clothing and equipment worn or carried, excluding trapeze harness, socks and shoes, must not exceed a maximum of 10.0 kg

**Helmsman:** Total weight of clothing and equipment worn must not exceed a maximum of 7.0 kg; weighed as for the **crew**.

**115. RRS 42 Propulsion** All of **RRS 42.3(c)** is altered (as permitted by **RRS 86.1 (c)**) to read as follows:

On a free leg of the course, the following actions are permitted for the sole purpose of accelerating a **boat** down the face of a wave (surfing) or, when planing conditions exist, responding to an increase in the velocity of the wind:

Not more than a maximum of three rapidly-repeated trims and releases of any **sail** (pumping). There must be no further pumping with respect to that wave or increase of wind.

***Equipment required for measurement.***

- a. Copy of current **Class rules** and Mylar measurement plan
- b. Triplicate measurement form (White, green. and blue)
- c. Stamps for marking the **boat** and gear
- d. Self-adhesive paper (pencil etc.) for marking station points
- e. Set of certified official templates
- f. 3 padded trestles
- g. Accurate weighing machine (up to 150 kg, 0.1 kg)
- h. Accurate weighing machine (up to 15 kg, 0.1 kg)
- i. 7 m fine strong thin line
- j. 10 m steel tape
- k. 2 or 3 m steel tape
- l. Two 150 mm, 0.5 mm steel rules
- m. Micrometer
- n. Callipers of the inside and outside type
- o. Centreboard thickness gauge (23 mm)
- p. Feeler gauges, 0.10 and 2.0 mm
- q. 2 mm feeler
- r. 1000 mm straight edge
- s. 1100 mm flexible batten



# Appendices

These appendices are not to scale and in the event of discrepancies between these appendices and the written rules, the written rules shall take precedence.

## Flying Dutchman Dimensions

Deck Length 6.055 m  
 Length LOA 6.050 m  
 Length DWL 5.500 m  
 Beam ~1.78 m

Hull Weight 130.0 kg  
 Sailing Weight ~165.0 kg

Mainsail ~10.2 m<sup>2</sup>  
 Genoa ~8.4 m<sup>2</sup>  
 Spinnaker ~21 m<sup>2</sup>

**MAINSAIL**  
 1 Advert both sides  
 Below sail letters & Numbers  
 Max. Length 1900 mm  
 Max. Height 620 mm  
 Clearly separated from  
 sail letters and numbers

**SPARS**  
 1 Advert on both sides  
 Mast: Max. Length 950 mm  
 Boom: Max. Length 470 mm

**HULL**  
 1 Advert on both sides  
 Max. Length 2250 mm

## Appendix A

**Advertising, Rule 1.4**  
 Allowed as per:  
 WS Regulation 20, with 20.3.2  
 restricted as shown below

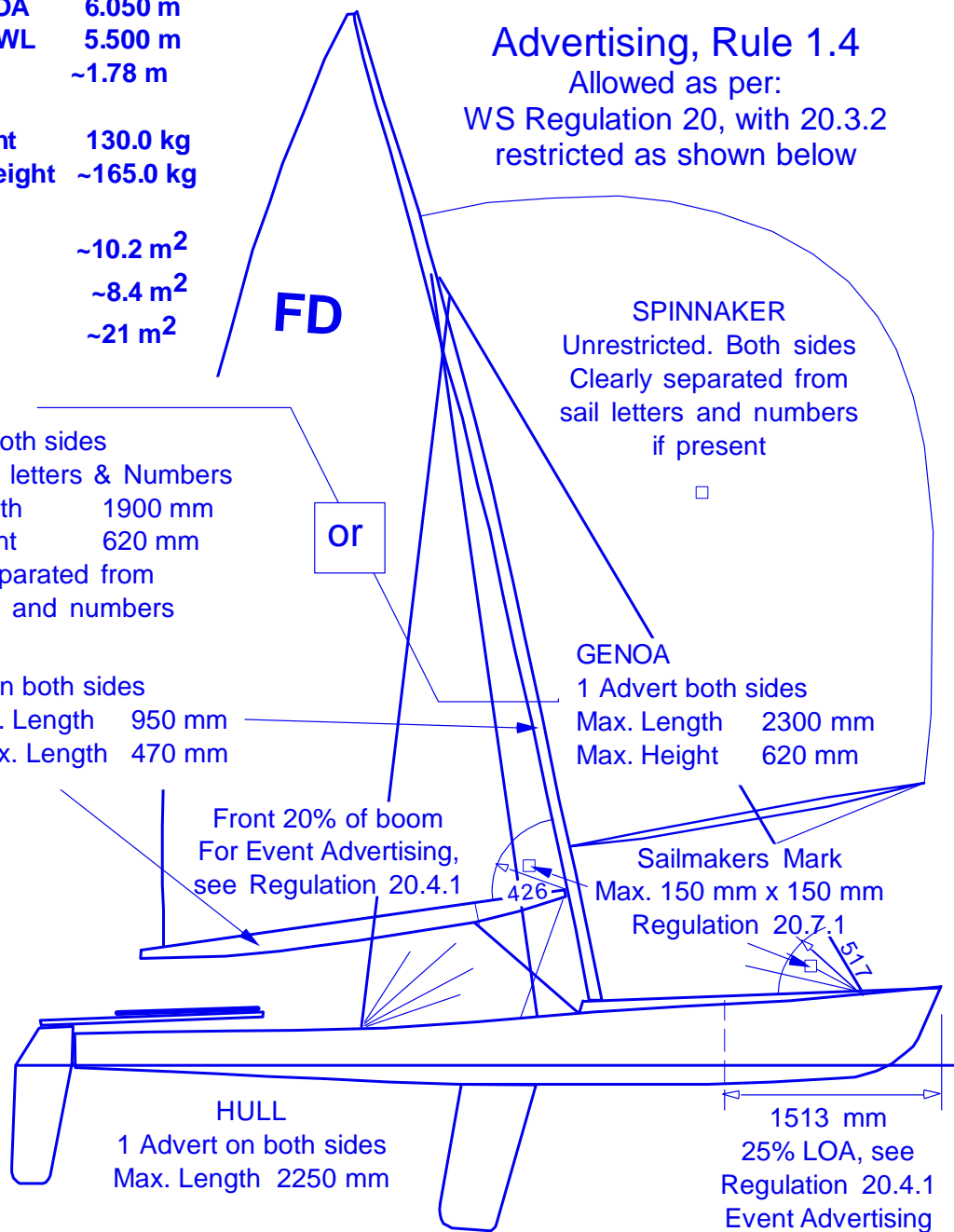

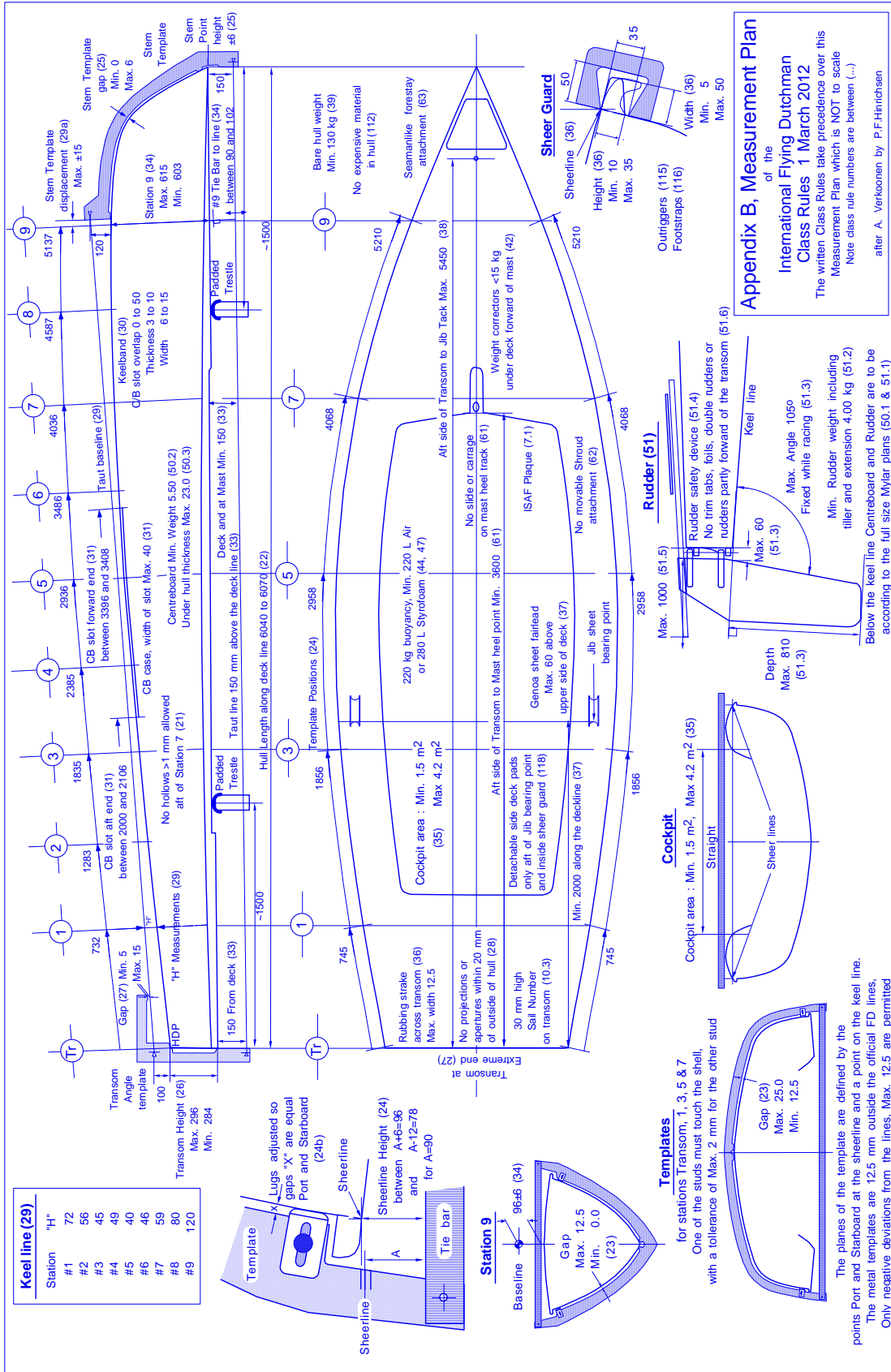

# Appendix C Genoa Sheet Fairlead Class Rule 37

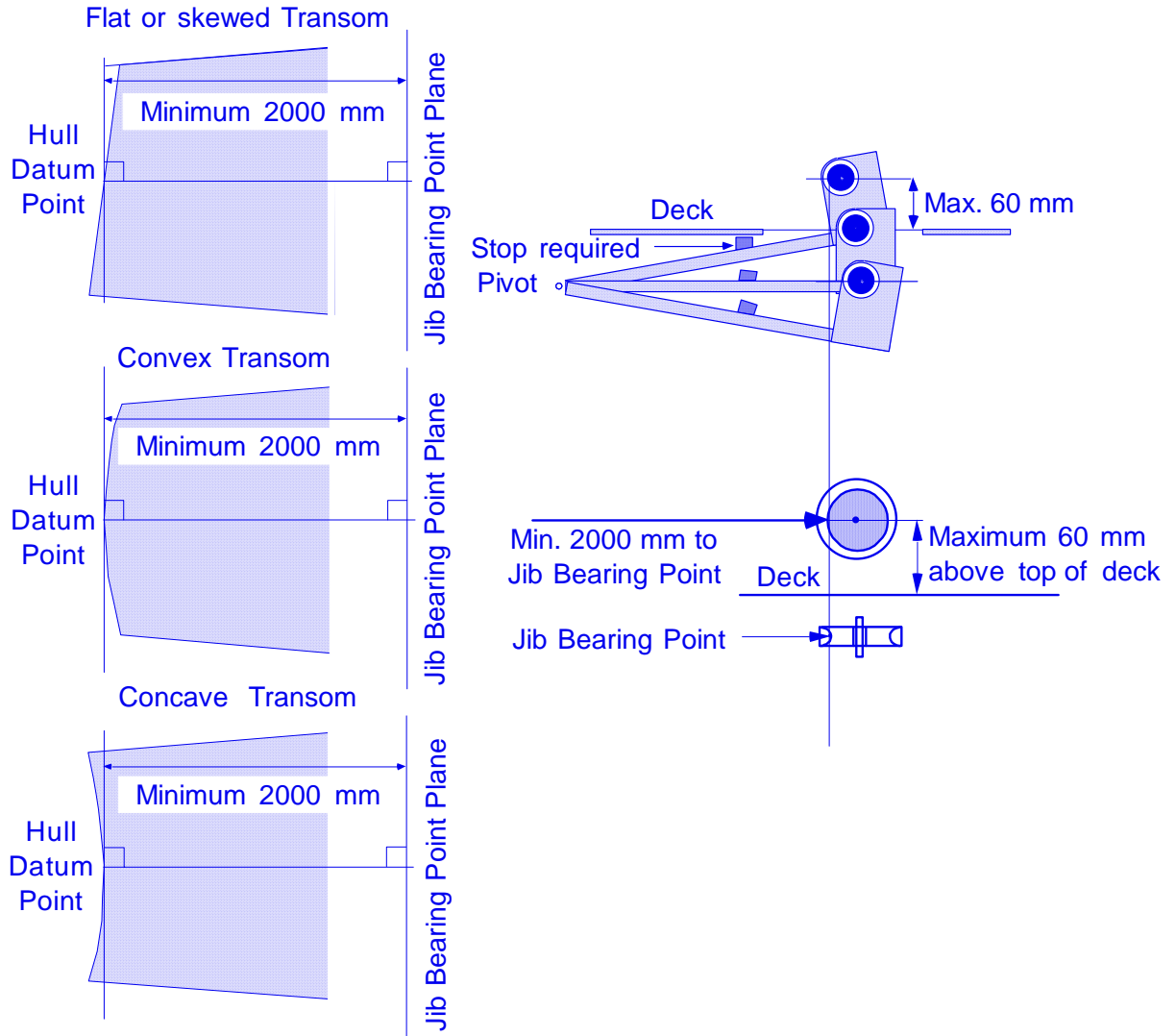

## Appendix D Jib/Genoa Rules 37-38

Note: The Jib/Genoa is not measured,  
but must fit within the dimensions  
specified on the hull and mast

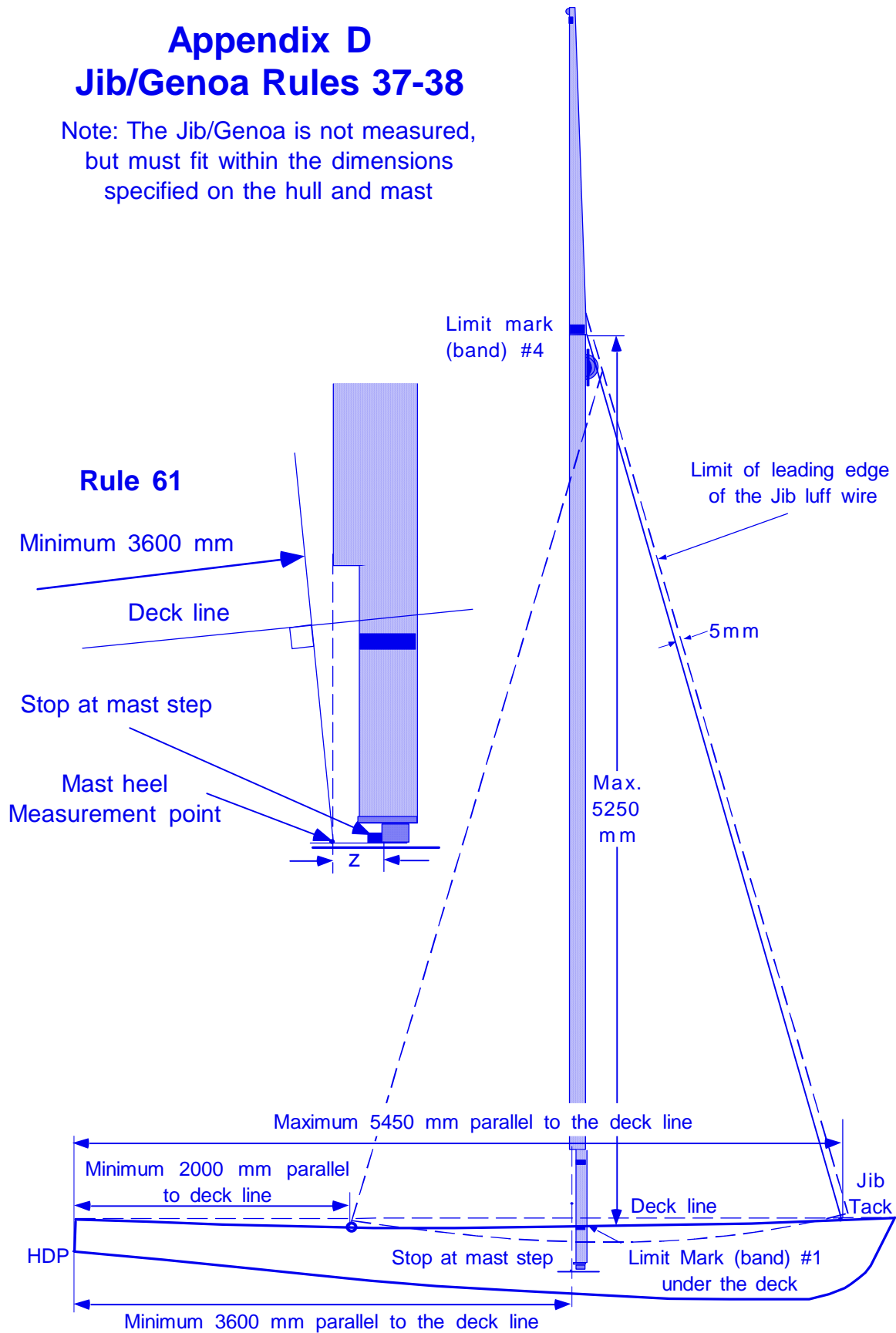

# Appendix E

## Genoa Rule 38, Mast and Boom Rules 57-72

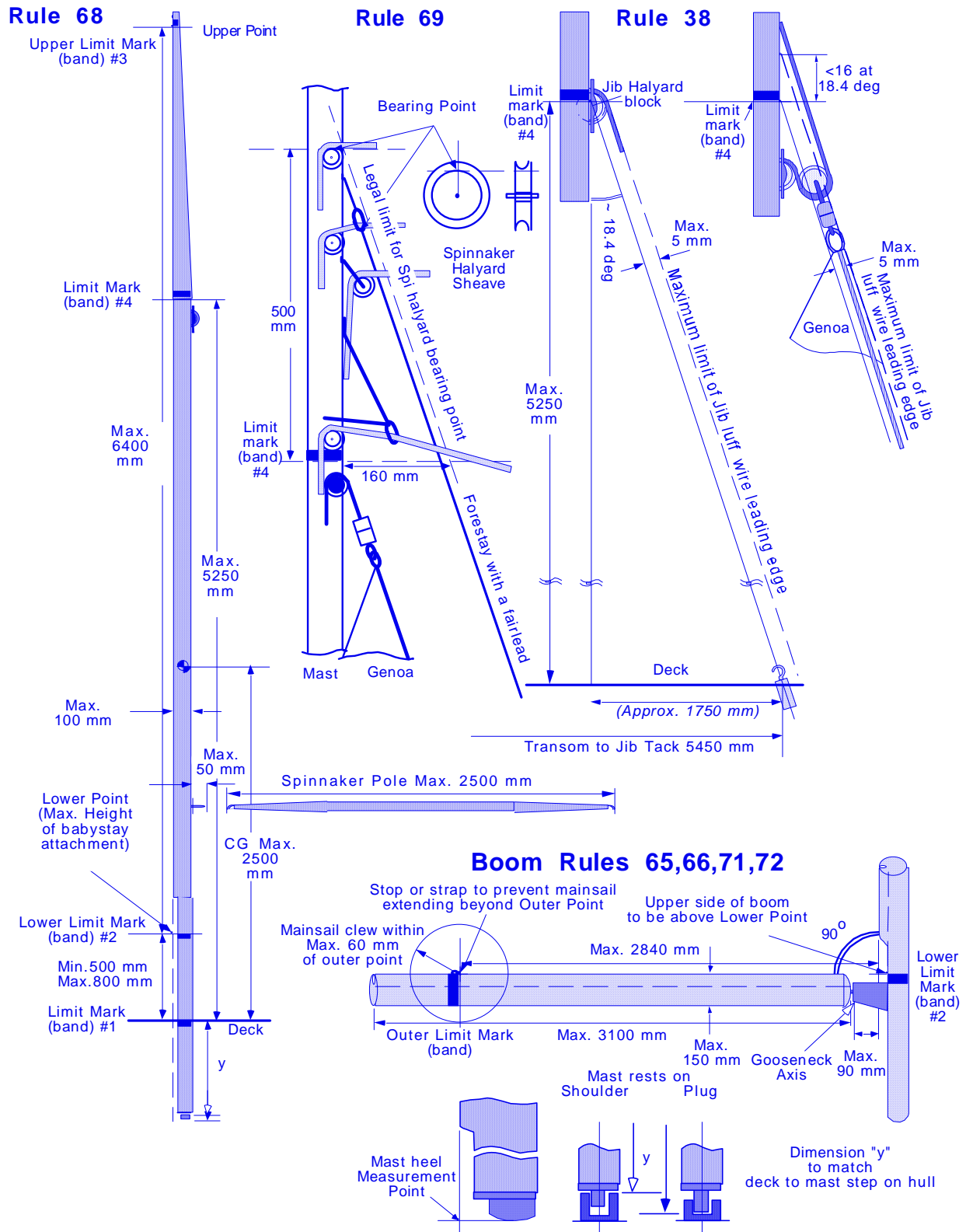

## Appendix F

### Centreboard and Rudder Rules 50-51

Centreboard	Max. thickness 23.0 mm
Rule 50	Min. weight 5.50 kg

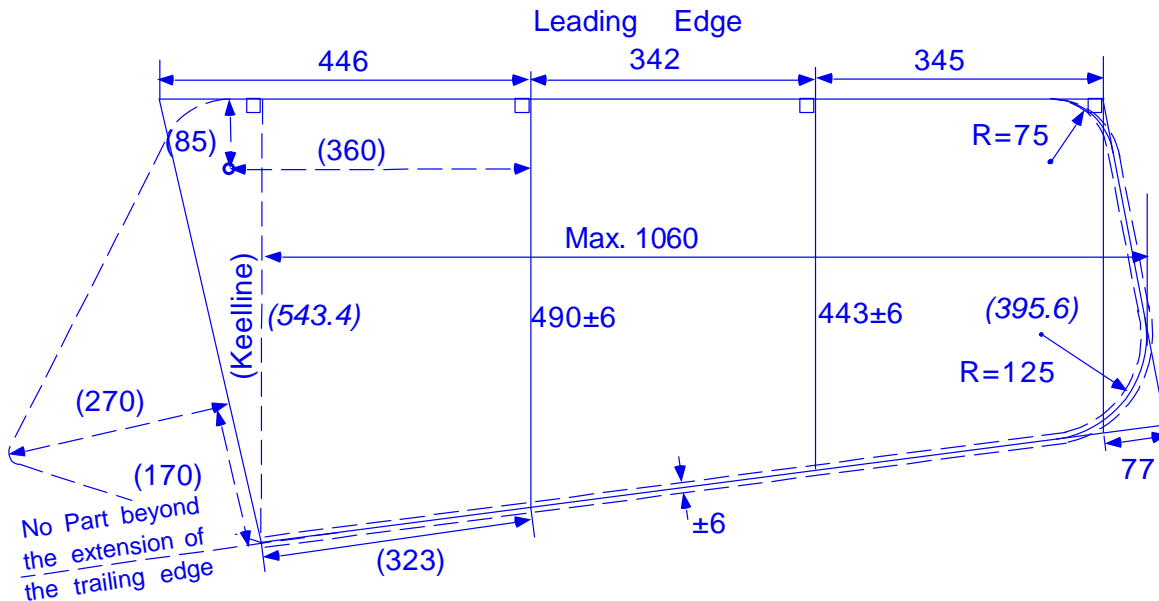

Rudder	Thickness: free
Rule 51	Min. weight: 4.0 kg (including tiller and extension)

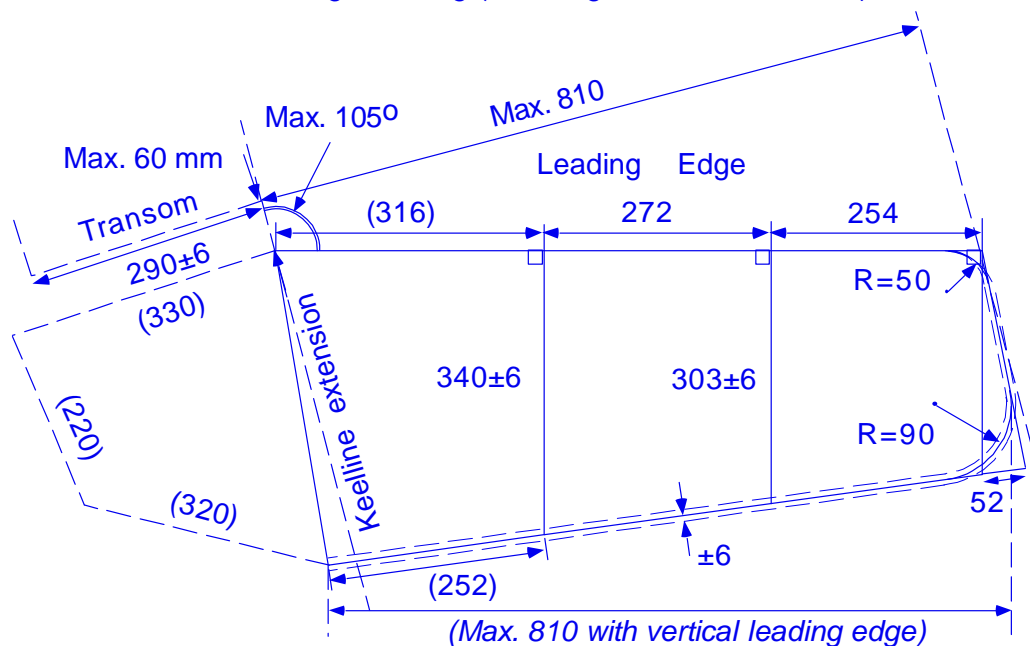

Notes: Only under keel line part must conform  
 Dashed lines are advised shapes and dimensions only  
 Keel line drawn perpendicular to C/B leading edge, at Max. depth.  
 Leading edge of rudder drawn at 105° to keel line, at Max. Depth  
 Dimensions in mm, (suggested in brackets), *(derived in italics)*.

### Appendix G Mainsail Rules 96-101

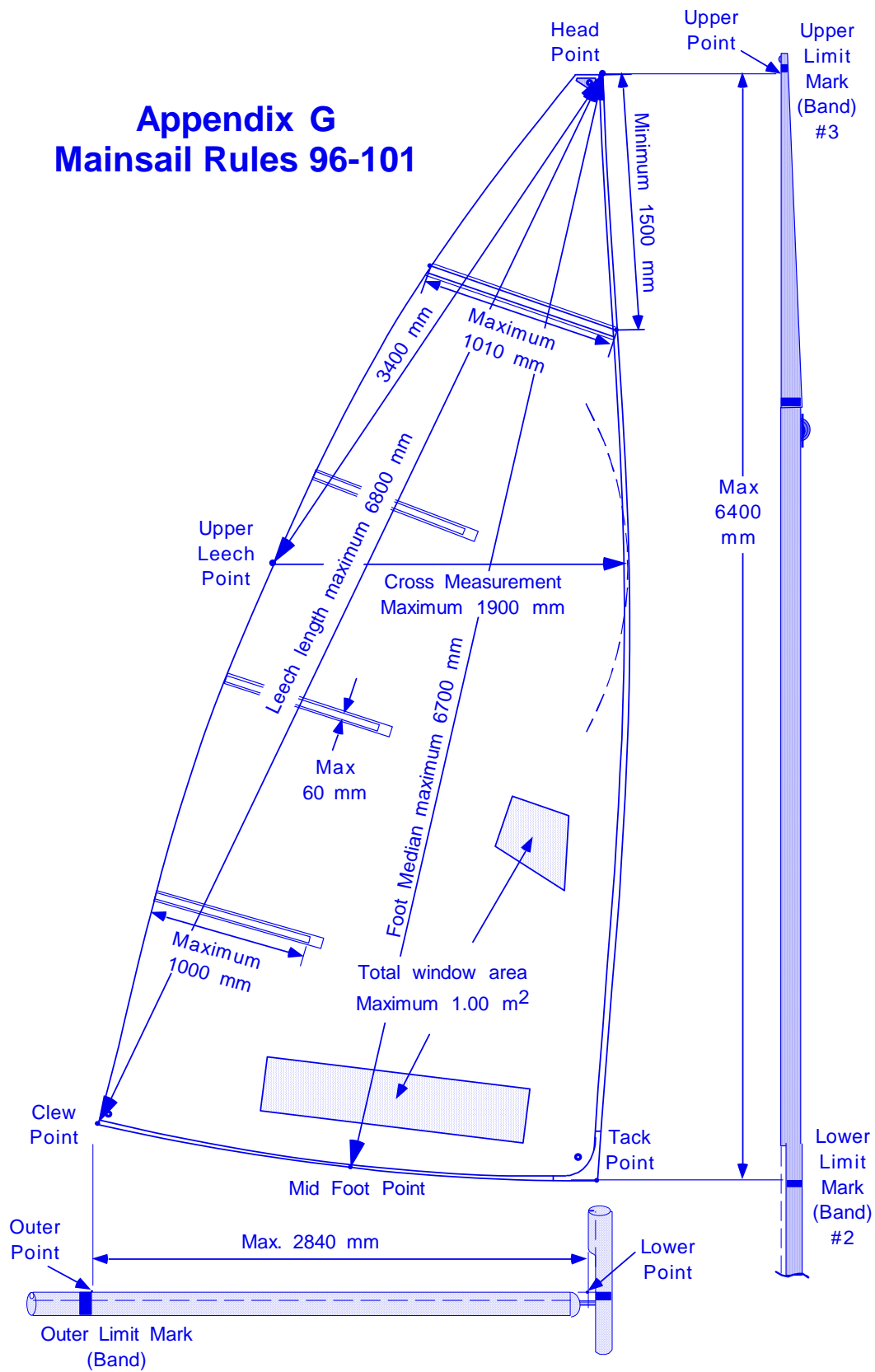

## Appendix H Mainsail Rules 95 and 99

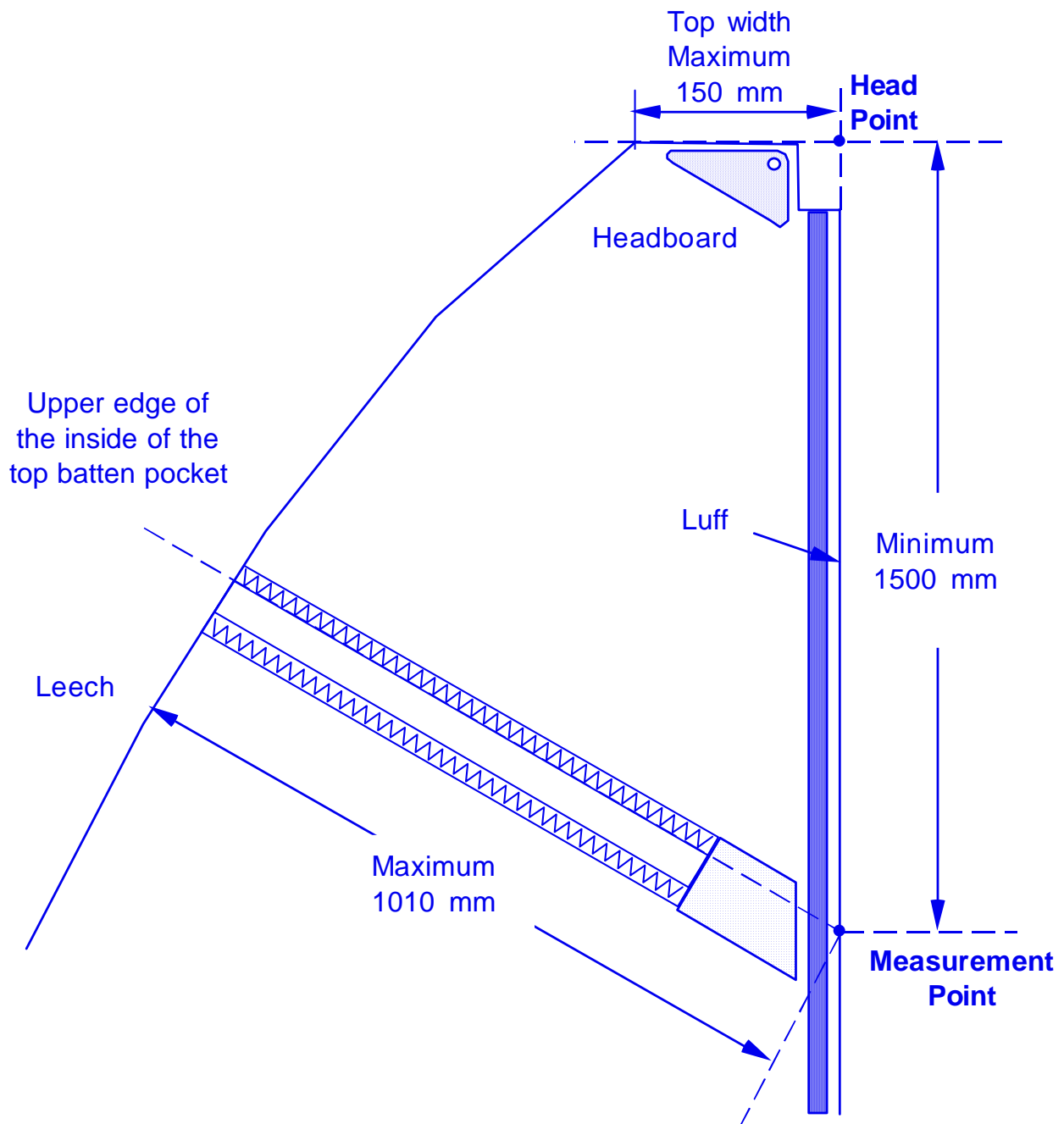



## Appendix I

# Spinnaker Rules 102-108

Rule 102 Spinnaker must be symmetrical in form and construction

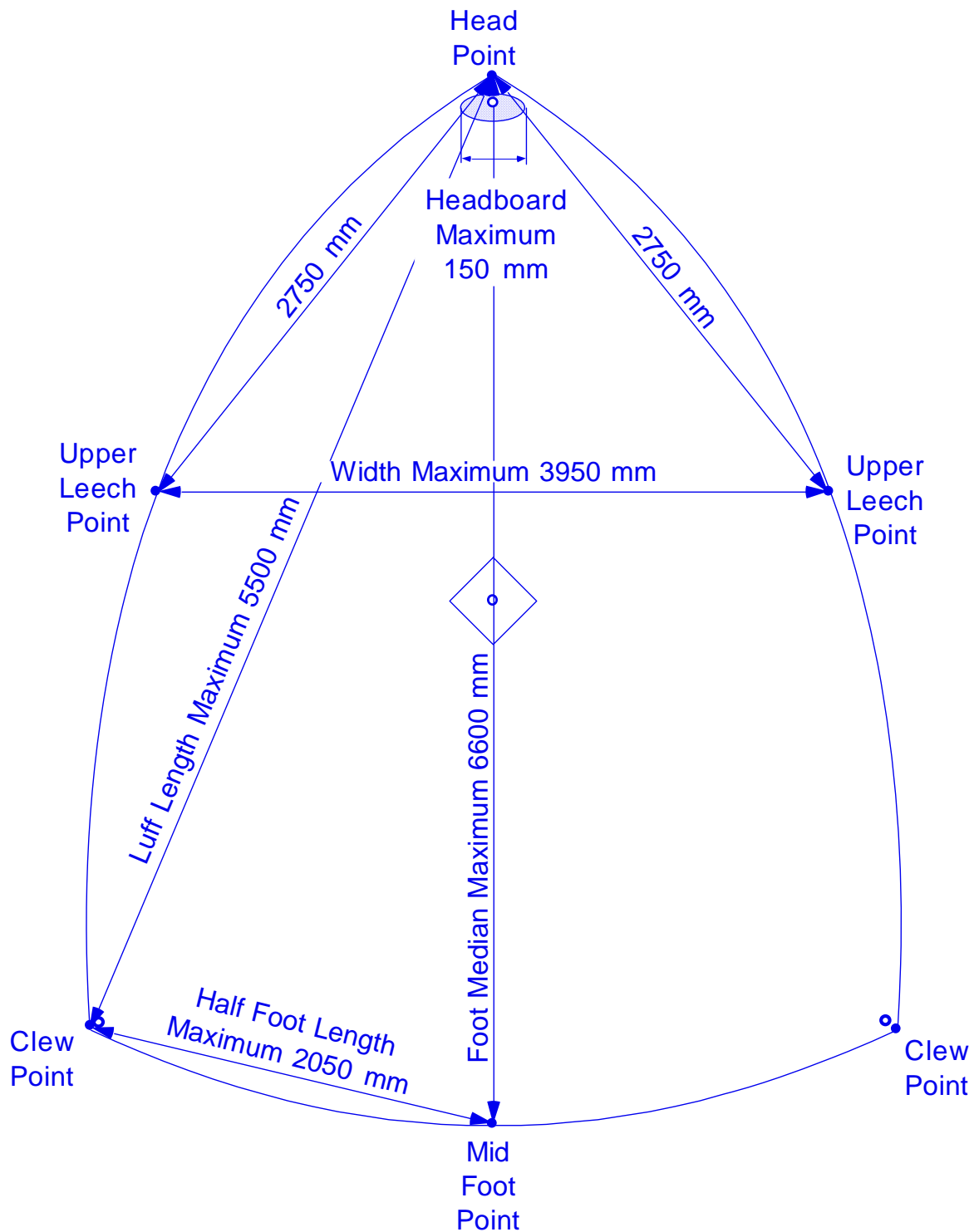

# Appendix J

Full size drawing, AutoCad file and Spreadsheet of Bezier curves available from IFDCO

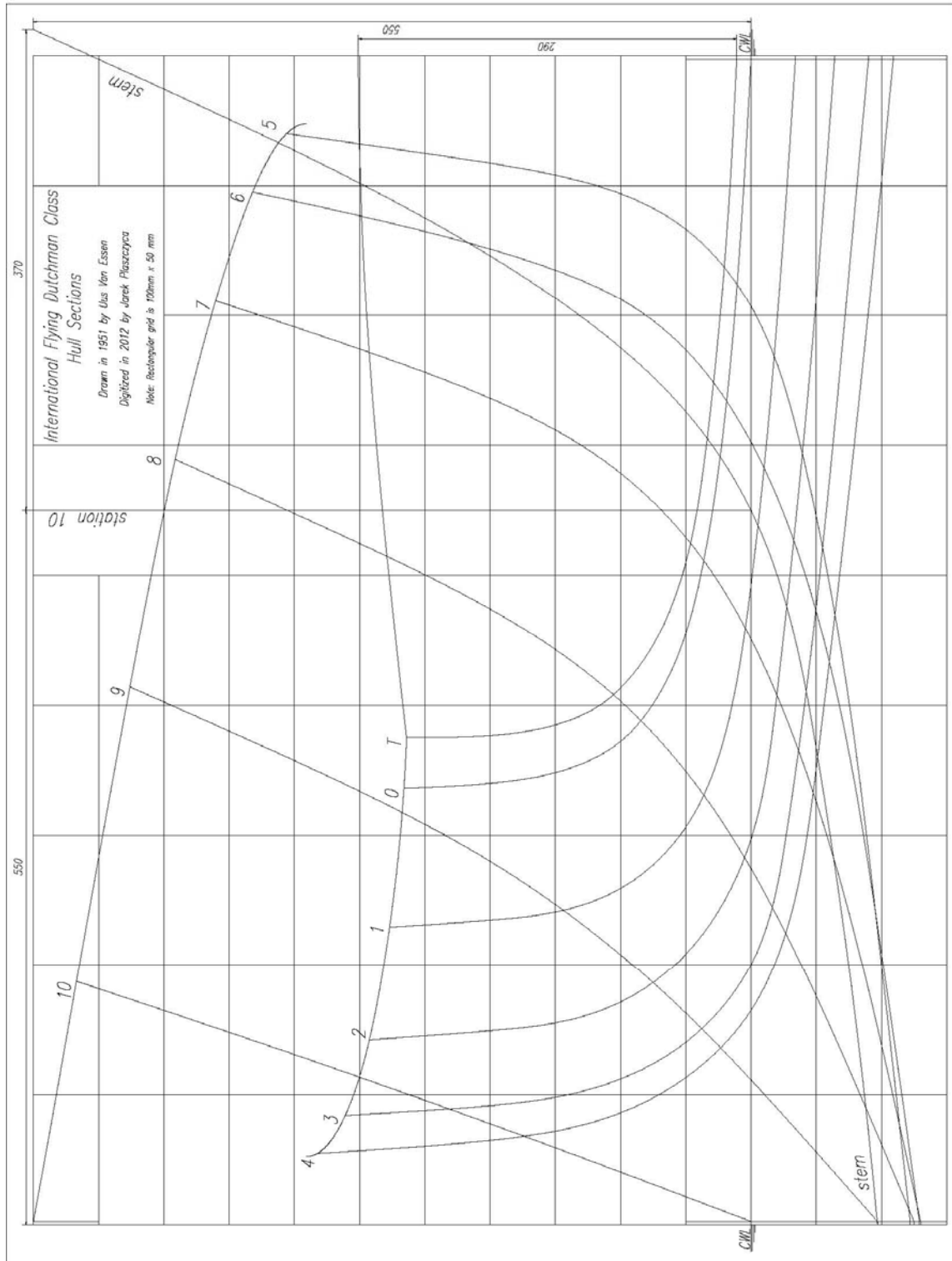



Appendix L Table of FD Offsets in mm																	
	Station	Transom	0	1	2	3	4	5	6	7	8	9	10	Stem Pt.	Stem behind Stem Point		
Z	Posn. Fwd.	0	180	730	1280	1830	2380	2930	3480	4030	4580	5130	5680	6050	Z	ord 11	X
550	Waterline #													3	550	0	6050
500	1												181.5		500	23	6027
450	1.5											402.5	164.5		450	45.5	6004.5
400	2									707.5	570.5	380	148		400	69	5981
350	2.5						839	788	788	691	548	357.5	130.5		350	93	5957
300	3					815.5	843	831.5	777.5	674	525	333	113		300	118	5932
250	3.5	525	563.5	669	755	812.5	839.5	824.5	765	655.5	500.5	308.5	95.5		250	145	5905
200	4	524	560	665.5	751	808.5	835	817	751.5	635	473	280	78		200	174	5876
150	4.5	515	552	659	745	802	828	807	735	611	442	247.5	60		150	207	5843
100	5	487	528	641	729	788	814	793	712.5	578.5	403	208	41.5		100	245	5805
50	5.5	390.5	446.5	594	691.5	760	787	767.5	672.5	530	349.5	163	22		50	294	5756
0	6		3	407.5	603	700	735.5	707	603	451	274.5	111	3	cwl	0	370	5680
-50	6.5				187.5	424	548	545.5	472	326	176.5	56			-50	553	5497
	sheer	525	564	670	758	816	845	840	795	711	589	414	187	sheer			
Y	Posn. Fwd.	0	180	730	1280	1830	2380	2930	3480	4030	4580	5130	5680	6050			
0-3	keel	11	0	-34	-64	-90	-109	-122	-129	-130	-125	-97	0	550			
100	0.5	16	5.5	-27.5	-57	-81	-99.5	-111	-115.5	-108.5	-84.5	-10.5	262				
200	1	23.5	12.5	-20.5	-49	-72.5	-90	-100	-101.5	-85.5	-39	90.5					
300	1.5	34.5	22.5	-11.5	-40	-62.5	-79.5	-89	-86	-58	15	234					
400	2	52.5	38.5	-1	-30	-52.5	-68	-75	-68	-23	96.5	444					
500	2.5	115.5	75.5	14.5	-18	-41	-56	-59	-41.5	28	249						
600	3			54	-1	-27	-42.5	-37	-1.5	131.5							
700	3.5				58	0	-18	-3.5	81	376							
	sheer	264	266	277	292.5	312	332.5	356	382	410	441.5	476	517	550			

Half Breadth to outside planking

from cwl to outside planking

Waterlines

Verticals